

Type CR Case Resistors - 100 to 400 Watts

APPLICATION

Powerohm's Type CR Case Resistors can be used in any AC or DC power circuit. Units are most commonly used for light-duty braking of variable frequency drives, space heating and any other low wattage load applications.

The Type CR resistors are suitable for intermittent and continuous duty applications requiring relatively high resistance and low wattage. The compact size of this unit makes it ideal for an installation where space is a premium. This unit can withstand extreme shock, qualifying it for nearly any high vibration application.

BASIC CONSTRUCTION

Powerohm's Type CR resistors are manufactured with quality components for superior performance and increased life expectancy. Our case resistors feature a nickel-chromium wire helically wound, then placed inside a ceramic fixture and inserted into a corrosion resistant aluminum case. Each coil end is terminated to high temperature wire leads and encapsulated with a ceramic potting material. The result is a resistor element electrically isolated, but thermally bound to the outer case to allow the element heat to transfer to the metallic case and efficiently cool. The units are supplied with wire leads, and the case is machined to include two mounting holes for easy installation.

Our ceramic insulating cores are manufactured in-house to maintain total control over production and quality standards. Powerohm is the only domestic resistor manufacturer with this added advantage.

OPTIONS

CUSTOM SIZES: Type CR resistors are normally available in (5) standard sizes with values between 100 to 400 watts per assembly. The overall size of the case determines the wattage rating and can be varied to meet specific ratings if necessary. Also, these units can be custom wound to any resistance value as long as it remains within the resistance ranges listed in the table on the following page.

CUSTOM LEADS: The standard lead length can be varied and the ends can be furnished with ring or fork terminals and male or female disconnects.

Type CR Case Resistor



ELECTRICAL CHARACTERISTICS

VOLTAGE INSULATION: A standard Type CR resistor is insulated for up to 1000 volts maximum.

RESISTANCE TOLERANCE: + 10% for all units; as low as + 3% if required.

COEFFICIENT OF RESISTIVITY: Resistance values will increase as the element temperature rises. Expect an approximate increase of 5% in resistance after the unit reaches an operating temperature of 375°C above ambient. Contact the factory for more specific information if needed.

AMBIENT TEMPERATURE: Standard ratings are based on maximum ambient temperatures of 40°C. Derate wattage rating 90% for 50°C ambient, 80% for 80°C ambient and 70% for 100°C ambient.

EFFECTS OF ALTITUDE: The published electrical ratings are applicable for altitudes of 6000 feet or less. Contact the factory for deration factors above 6000 feet.

CUSTOM DESIGNS

Powerohm offers a complete selection of standard size units. Numerous variations are available for almost any application. Please contact the factory if there are special service requirements, such as overloads, high peak currents, high ambient temperatures, etc.

Type CR Electrical Ratings & Dimensions

SPECIFY PART NUMBERS AS FOLLOWS: CR - -

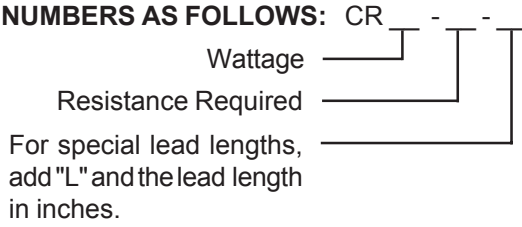

For example, the part number for a 100 watt, 20 ohm unit with standard 18 inch leads is CR100-20. The catalog number for the same resistor with a custom lead length of 36 inches is CR100-20-L36.

RATINGS: The continuous current ratings are based on a 375°C temperature rise. The resistance values are measured at 25°C and have a + 10% tolerance.

ELECTRICAL RATINGS & DIMENSIONS OF STANDARD SIZE CASE RESISTORS

WATTAGE	RESISTANCE RANGE (OHMS)	DIMENSIONS IN INCHES				
		A	B	C	D	E
100	5 - 375	6	1-1/2	3/4	5-1/2	3/4
150	10 - 750	9	1-1/2	3/4	8-1/2	3/4
200	20 - 1000	6	3	1-1/2	5-1/2	1-1/2
300	30 - 1500	9	3	1-1/2	8-1/2	1-1/2
400	40 - 2000	12	3	1-1/2	11-1/2	1-1/2

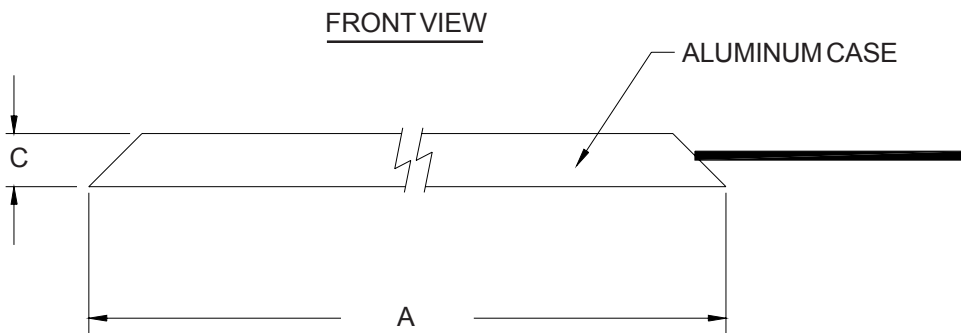
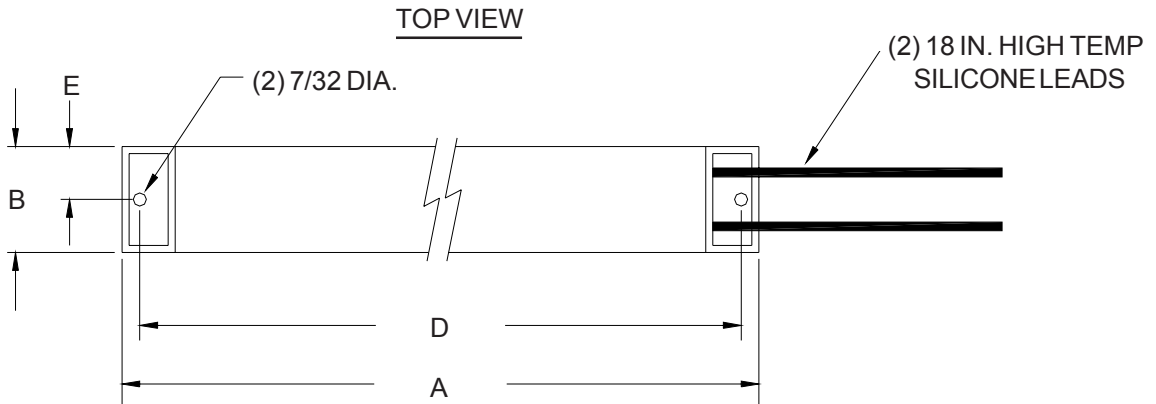

24 HOUR EMERGENCY SERVICE

(800) 838-4694